

# Refrigerator

Instructions for installation and use

**GS 164 I UK**

 **INDESIT**



**GB** 0-star refrigerator

Instructions for installation and use



**To maintain the EFFICIENCY and SAFETY of this appliance, we recommend:**

- use only the MANUFACTURER Service
- use only ORIGINAL Spare Parts

# Safety - a good habit to get into.

## ATTENTION

Read your manual carefully since it contains instructions which will ensure safe installation, use and maintenance of your appliance.

Your Refrigerator is built to International safety standards (EN60) and has been awarded the European approval mark (IMQ) for compliance with UK electrical safety requirements. It also meets the EC standards on the prevention and elimination of radio interference (EC directive 87/308 - 02.06.89).

1. This appliance must not be installed outdoors - not even in an area protected by a roof. It is extremely dangerous to leave it exposed to rain or storms.
2. It must only be used by adults and exclusively to refrigerate and freeze foodstuffs, following the instructions for use contained in this manual.
3. Do not ever touch or handle the appliance with bare feet or with wet hands or feet.
4. It is highly recommended that you do not use extension cords or multiple socket adapters. If the refrigerator is installed between cabinets, make sure that the cord is not bent or dangerously pinched or compressed.
5. Never pull on the cord or the refrigerator to remove the plug from the wall socket - this is very dangerous.
6. Never touch the cooling components within the appliance, especially with wet hands because this could result in injury. Never put ice cubes just removed from the freezer

into your mouth because they could stick to your mouth and cause burns.

7. Never clean the appliance or perform maintenance without first disconnecting it from the electrical mains. Turning the thermostat knob to the ● setting does not suffice to break all electrical contact with the mains.

8. Before having your old refrigerator picked up for disposal, remove or make inoperable any locking devices to prevent children who might play in or around the appliance from being locked inside.

9. Before calling for service/assistance in the case of malfunction, consult the chapter entitled "Is There a Problem?" to determine whether it is possible to eliminate the problem. Do not try to repair the problem by trying to access the internal components of the appliance.

10. If damaged, the power supply cord on this appliance must necessarily be replaced by our service centre because special tools are required for replacement.

11. Do not use electric appliances inside the compartment for food storage, if these are not those recommended by the manufacturer.

12. At the end of the functional life of your appliance – containing cyclopentane gas in the insulation foam and perhaps gas R600a (isobutane) in the refrigeration circuit – the latter should be made safe before being sent to the dump. For this operation, please contact your dealer or the Local Organisation in charge of waste disposal.

## Installation

**To ensure that the appliance operates properly and to reduce energy consumption, it is important that the appliance is installed correctly.**

### Ventilation

The compressor and condenser generate heat and, therefore, need to be ventilated properly. Rooms with less than perfect ventilation are not very suited for installation of the appliance. Therefore, it should be installed in a room with an opening (window or French window) that provides the appropriate amount of air re-circulation. It is also important that the room not be too humid.

During installation, make sure not to cover or obstruct the grates that allow for proper ventilation of the appliance.

### Away from Heat

Avoid positioning the appliance in a place where it is directly exposed to sunlight or near an oven, cook top or the like.

### Level

The appliance must be level. If the floor is not level, the adjustable feet located in front can be used to level the appliance.

### Electrical Connection and Earthing

Before proceeding with the electrical connection, make sure that the voltage indicated on the rating plate, located at the

bottom left near the vegetable crisper, corresponds to the mains voltage in your home and that the socket is fitted with a standard earthing wire in accordance with safety standards for 46/90 systems. If the socket is not fitted with an earthing wire, the manufacturer will not be held liable for any damages and or injuries arising out of the use of the appliance. Do not use multiple sockets or adapters.

### Insufficient power?

The electrical socket must be able to handle the maximum power load of the appliance, which is indicated on the rating plate located at the bottom left next to the vegetable crisper.

### Before making the electrical connection ...

After the appliance has been delivered, place it in the vertical upright position and wait at least 3 hours before inserting the plug into the socket in order to ensure that it functions properly.

### For English Market only

The appliance is fitted with a continental 2-pin plug for factory testing. Before installation the plug should be cut off. The appliance is designed to be installed in a switched spur outlet fused at 13 Ampere. If the installation requires a 13 Ampere plug type to be fitted it should conform to BSI 1363.

## Electrical connection

Your appliance is now supplied with a 13 amp fused plug that can be plugged into a 13 amp socket for immediate use. Before using the appliance please read the instructions below.

**WARNING - THIS APPLIANCE MUST BE EARTHED. THE FOLLOWING OPERATIONS SHOULD BE CARRIED OUT BY A QUALIFIED ELECTRICIAN.**

### Replacing the fuse:

When replacing a faulty fuse, a 13 amp ASTA approved fuse to BS 1362 should always be used, and the fuse cover re-fitted. If the fuse cover is lost, the plug must not be used until a replacement is obtained.

### Replacement fuse covers:

If a replacement fuse cover is fitted, it must be of the correct colour as indicated by the coloured marking or the colour that is embossed in words on the base of the plug. Replacements can be obtained directly from your nearest Service Depot.

### Removing the plug:

If your appliance has a non-rewireable moulded plug and you should wish to remove it to add a cable extension or to re-route the mains cable through partitions, units etc., please ensure that either:

- the plug is replaced by a fused 13 amp re-wireable plug bearing the BSI mark of approval
- or:
- the mains cable is wired directly into a 13 amp cable outlet, controlled by a switch, (in compliance with BS 5733) which is accessible without moving the appliance.

### Disposing of the plug:

Ensure that before disposing of the plug itself, you make the pins unusable so that it cannot be accidentally inserted into a socket. **Instructions for connecting cable to an alternative plug:**

Important: the wires in the mains lead are coloured in accordance with the following code:

- |                |           |
|----------------|-----------|
| Green & Yellow | - Earth   |
| Blue           | - Neutral |
| Brown          | - Live    |

As the colours of the wires in the mains lead may not correspond with the coloured markings identifying the terminals in your plug, proceed as follows:

Connect Green & Yellow wire to terminal marked "E" or  or coloured Green or Green & Yellow.

Connect Brown wire to terminal marked "L" or coloured Red.

Connect Blue wire to terminal marked "N" or coloured Black.

If a 13 amp plug (BS 1363) is used it must be fitted with a 13 amp fuse. A 15 amp plug must be protected by a 15 amp fuse, either in the plug or adaptor or at the distribution board. If you are in any doubt about the electrical supply to your machine, consult a qualified electrician before use.

### How to connect an alternative plug:

The wires in this mains lead are coloured in accordance with the following code:

- |                  |                     |
|------------------|---------------------|
| BLUE             | " NEUTRAL " (" N ") |
| BROWN            | " LIVE " (" L ")    |
| GREEN AND YELLOW | " EARTH " (" E ")   |

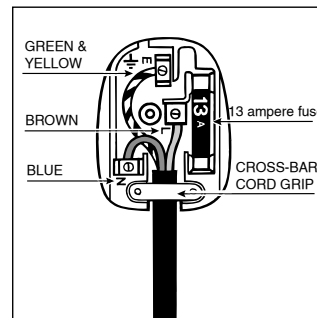

### Disposing of the appliance:

When disposing of the appliance please remove the plug by cutting the mains cable as close as possible to the plug body and dispose of it as described above.

# A closer look

## **A** Temperature regulation knob

Use this knob to regulate the temperature of the refrigerator. The following settings are available:

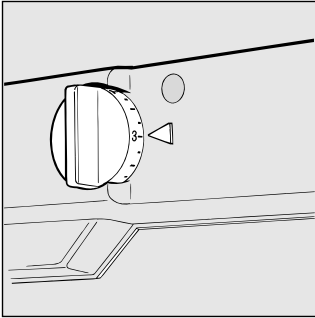

- refrigerator OFF;
  - 1 minimum cold temperature;
  - 5 maximum cold temperature
- You can position the knob on any of the settings from 1 - 5 as required. Remember that you can turn off your refrigerator by setting the knob to ●.

## **C** Door Shelf with Egg Compartment

## **D** Tiltable Door Shelf for Food Products

## **E** Sliding Bottle Divider

## **F** Door Shelf for Holding Bottles

## **G** Fruit and Vegetable Crisper

## **H** Drain for Defrost Water

## **I** Removable, Height-adjustable Shelves

## **B** Container with Lid for Butter, Small Tins and Tubes

## **J** Compartment for storing frozen foods, freezing fresh foods and making ice

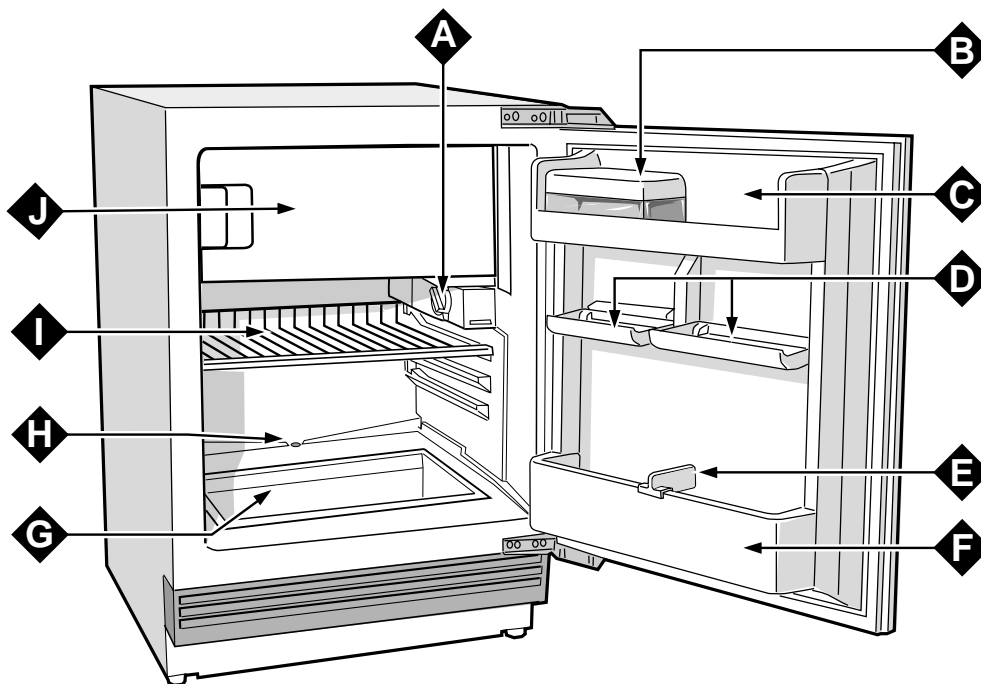

# Setting up Your Appliance

## ATTENTION

After transport stand the appliance upright and wait at least 3 hours before plugging the appliance into the mains to ensure proper performance.

Use these average temperature settings to ensure optimum performance and to save energy.

Before storing food in your refrigerator wipe the interior with a solution of warm water and bicarbonate of soda.

After having plugged the appliance into the socket, make sure that the refrigerator light has turned on. Then turn the thermostat knob "A" to setting "3". After a couple of hours, you can place fresh food into the refrigerator.

Fill the ice trays and place them in the compartment "J".

# Storage - getting the most out of your appliance.

## Storing Food in the Refrigerator Compartment

Food	Storage Time	Location in the Refrigerator
Wrapped meat and cleaned fish (use plastic wrap or pack in plastic bags)	2 or 3 days	On the shelf above the vegetable crisper (which is the coldest area).
Fresh cheese	3 or 4 days	On the shelf above the vegetable crisper (which is the coldest area).
Eggs	1 month	In special egg rack on door.
Butter, margarine		On any shelf.
Cooked or precooked food (place in air-tight containers and when cool store in refrigerator)	3 or 4 days	On any shelf.
Sausages, salami, sandwich meats in general, fresh pasta, custards, puddings, chocolates, cream pastries, bread, dry pastries, red tomatoes	3 or 4 days	On any shelf.
Bottled products, milk, drinks, yoghurt		On special door shelves.
Fruits and legumes		In vegetable crisper.

## What Not to Store in the Refrigerator

Garlic (transmits odour), onions and leeks.

Bananas (they will turn black).

Citrus fruits.

Potatoes and root vegetables (store in dark, dry places).

- Air in the refrigerator circulates naturally so that colder, heavier air tends to descend towards the bottom. This is why meat and fish should be stored just above the crisper.

- Remember to follow our instructions on the storage life of foods: If not stored correctly, even the freshest food will deteriorate quite quickly.

- Contrary to popular belief, cooked foods do not keep longer than fresh food.

- Do not store liquids in unsealed containers since this will increase the humidity and lead to the formation of frost in the refrigerator.

## Freezing Foods Properly

### - For the preparation of food to be frozen, please consult a specialized manual.

- Food that has been thawed, even partially, must not be refrozen: you must cook it in order to consume it (within 24 hours) or to freeze it once again.

- Fresh foods that you intend to freeze must not be placed in contact with those that are already frozen or those that have been fast-frozen. Rather, they must be placed in the freezer compartment, in contact with the walls of the compartment (back or side) if possible. Please keep in mind that proper conservation of frozen foods depends on the speed with which they are frozen.

- During the freezing process, avoid opening the door of the freezer.

- The maximum daily quantity of food that can be frozen is indicated on the rating plate located to the left of the vegetable crisper.

- In order to freeze and then thaw foods optimally, it is recommended that you divide food into small portions so that they freeze quickly and uniformly. The packages should be clearly marked with the content and the date they were frozen.

- Do not open the freezer door in the event of a power failure or malfunction. This precaution will slow the rise in temperature within the compartment. If the door is not opened, frozen and fast-frozen foods will remain in their current state for approximately 9-14 hours.

- Do not place full bottles in the freezer: they could easily burst because all liquids increase in volume when they freeze.

- Fill the ice cube trays about 3/4 full.

- If the ambient temperature remains below 14°C for an extended period of time, the temperature needed for extended storage of food in the freezer will not be reached, resulting in reduced storage life of the food.

## Energy Saving Tips

### - Install the Appliance Correctly

This means that the appliance should be installed away from heat sources or direct sunlight in a well ventilated room.

### - Correct Temperature Settings

Set the refrigerator temperature knob to one of the middle settings. Very cold temperature settings will not only consume a great deal of energy but will neither improve nor lengthen the storage life of the food. Excessively cold temperatures may ruin vegetables, cold cuts and cheese.

### - Do Not Overfill Your Appliance

Remember that proper storage of food requires good air circulation. Overfilling your appliance will hamper proper air circulation and overwork the compressor.

### - Keep the Door Closed

Open the refrigerator only when necessary; remember that every time you open the door most of the cold air will be lost. To bring the temperature back to the proper level, the motor must run for a considerable amount of time, consuming a substantial amount of energy.

### - Check the Seal on the Door

Keep the seal clean and soft so that it fits tightly against the door to ensure that no cold air is lost.

### - Never Put Food in the Refrigerator while Still Hot

A container of hot food in the refrigerator will increase the temperature significantly; allow food to cool to room temperature before storing.

# Caring for Your Appliance

Before doing any cleaning, disconnect the appliance from the electricity (by pulling out the plug or turning off the general switch in your home).

## Defrosting

**WARNING: do not damage the refrigeration circuit. Do not use mechanical devices or instruments other than those recommended by the manufacturer to speed up the defrosting process.**

The evaporator defrosts automatically during operation; the defrost water is collected by the conveyor and is evaporated externally automatically.

Clean the defrost water drain hole periodically (see fig. 1) to prevent the water from collecting on the bottom of the refrigerator instead of flowing out.

The storage compartment should be defrosted when the layer of ice in the evaporator reaches the thickness of 7 to 8 mm. Set the thermostat knob on symbol "●" and leave the door open until the compartment is completely defrosted. The defrost water can be collected as shown in figure 2. Dry the wet parts and turn on the appliance by setting the thermostat knob on the setting used previously. To speed up the defrosting of the storage compartment, place a bowl of hot water inside the compartment.

**IMPORTANT:** When defrosting, remove the frozen food, wrap in newspaper and keep in a cool place.

Since the rise in temperature will shorten the storage life of the food, it should be used as soon as possible.

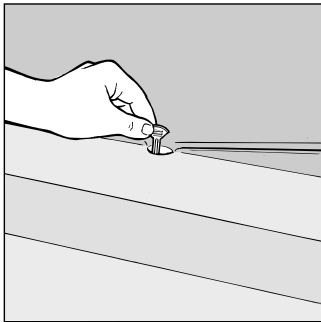

Fig. 1

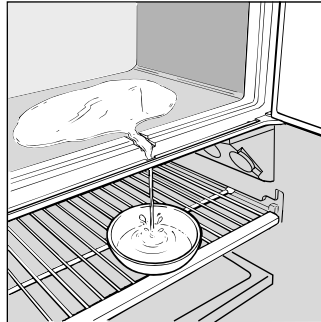

Fig. 2

## Cleaning and Maintenance

- Your appliance is manufactured with hygienic, odourless materials. To preserve these characteristics, always use sealed containers to store foods in order to prevent spills, stains and the formation of difficult to remove odours.

- Only use a water and bicarbonate solution to clean the appliance. Clean the internal and exterior of your appliance with a sponge soaked in a warm water and sodium bicarbonate solution, which is also a good disinfectant. If you do not have any sodium bicarbonate at home, use a neutral soap.

- What not to use: Do not use abrasive detergents, bleach or detergents containing ammonia. Never use solvent based products.

- All removable parts can be cleaned by soaking them in hot soapy water or detergent. Remember to dry them thoroughly before replacing them.

- Discontinued use of the appliance: If the appliance is not in use for any length of time, remember to clean the interior and dry thoroughly, leaving the door open to prevent the formation of odours and mould.

- Replacing the light bulb. The bulb for lighting the interior of the appliance is located at the back of the thermostat box. Unscrew the burned out bulb and replace it with another bulb with a wattage no higher than 15 Watt, follow the instructions illustrated in fig. 3.

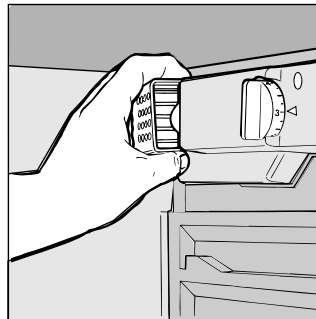

Fig. 3



# Trouble Shooting

## The Refrigerator does not Work

Check that:

- The mains switch in your home is on.

## The Appliance does not Refrigerate Properly

Check that:

- The door is shut properly and that the door seal is not damaged;
- The thermostat temperature knob is on the correct setting;
- The refrigerator has not been overfilled.

## Food in the Refrigerator is too Cold

Check that:

- The thermostat knob is on the correct setting.

## The Motor Runs Continuously

Check whether:

- The door is not closed properly or has been left open;
- The room temperature is not too high.

## The Appliance is Noisy

Check whether:

- The appliance is perfectly level;
- The appliance has been installed between cabinets or other objects that vibrate or make noise.

## There is Water on the Bottom of the Refrigerator

Check whether:

- The defrost drain is clogged.

Remember that the refrigerant in the cooling circuit causes a slight bubbling sound, even when the compressor is not running (this is quite normal).

If after all the checks, the appliance still does not operate or the problem persists, call the nearest Service Centre and inform them of: the type of problem, the abbreviation of the model name (Mod.) and the relative numbers (S/N) written on the rating plate located at the bottom left next to the vegetable crisper (see example in the figure below).

Mod. <b>RG 2330</b>		TI	Cod. <b>93139180000</b>		S/N <b>704211801</b>	
240 V-	50 Hz	150 W	W	Fuse A	Max 15	
Total	<b>340</b>	<b>75</b>			Freez. Capac	Class
Gross Bruto			Net Util Utile	Gross Bruto	Poder de Cong	Clase <b>N</b>
					kg/24 h <b>4,0</b>	Classe
Compr. Syst.	R 134 a	Test	Pressure HIGH-235			
Kompr.	kg 0,090	P.S.-I.	LOW 140			
Made in Italy 13918						

**Never call unauthorized personnel and insist on the use of original spare parts.**





# Merloni Elettrodomestici

Viale Aristide Merloni 47

60044 Fabriano

Italy

Tel +39 0732 6611

Fax +39 0732 662501

[www.merloni.com](http://www.merloni.com)